

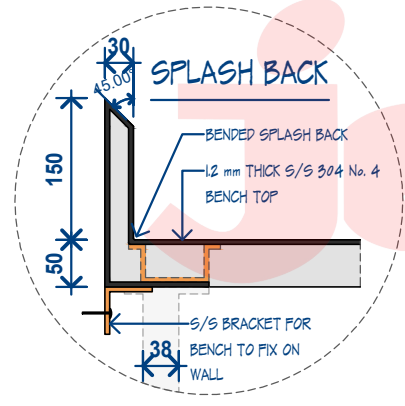

B-WB7-900

STAINLESS STEEL WALL BENCH WITH SPLASH BACK

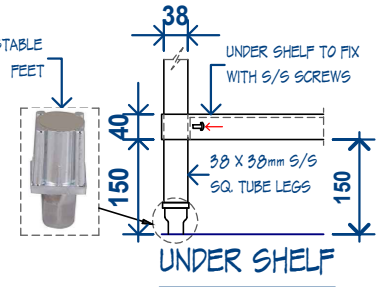
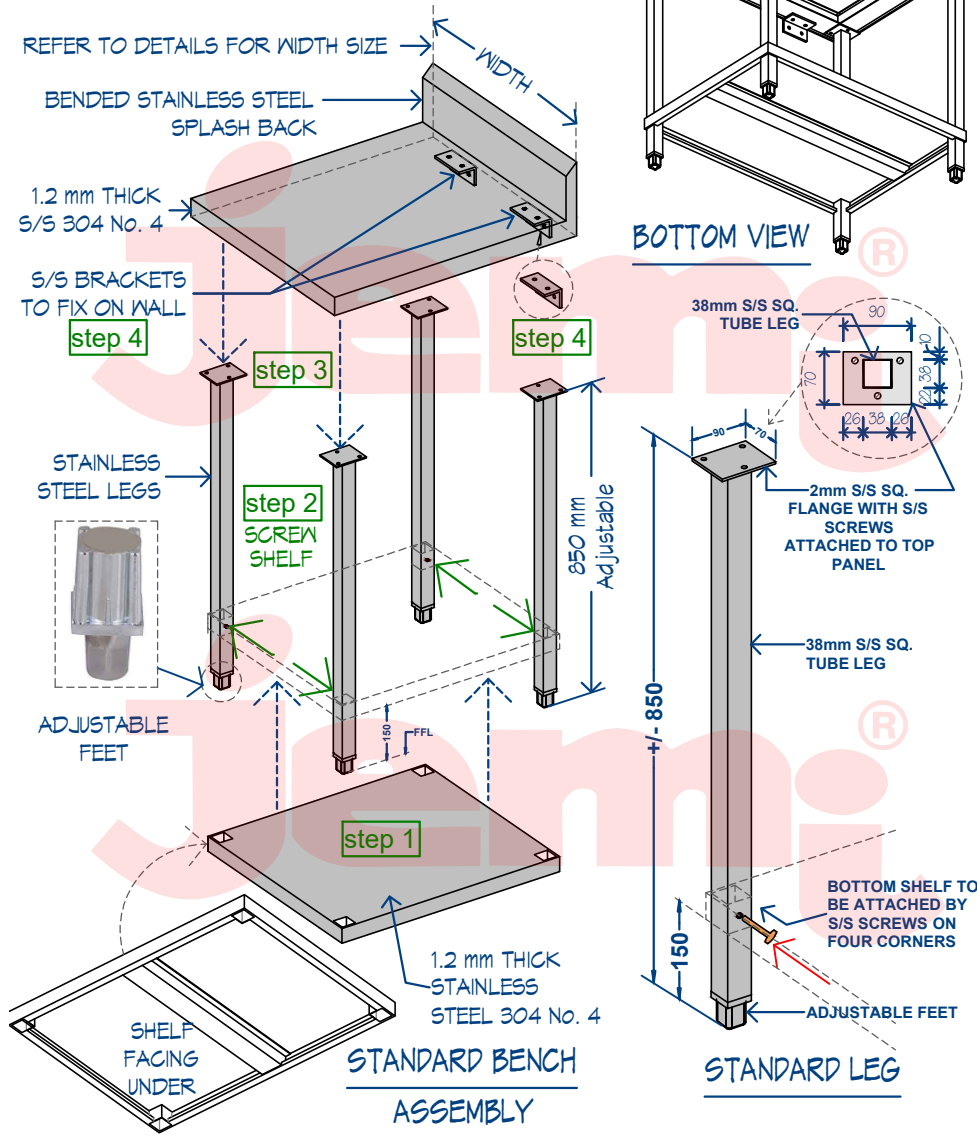

FEATURES:

- High quality Heavy duty full stainless kitchen benches
- **Top:** 1.2mm SUS 304 Top, Legs Sus 201
- Top hat stainless stiffening 1/4 " hex stainless steel screws make these units
- Second to none in strength and appearance

SPECIFICATIONS:

- **Feet:** Adjustable stainless feet (60mm ~ 70mm) 38mm square tube legs
- **Splash back :** 150mm H, 45° angle scaled back
- **Fascia:** 50mm rolled back edge
- **Under shelves:** Full Stainless under shelf and frames - 1.2mm construction with 40mm fascia all-round
- Easy to assemble, Easy to Clean
- **Bracket:** Fixing bracket to wall supplied
- **Dimensions:** W900 x D700 x H900 + 150mm splashback

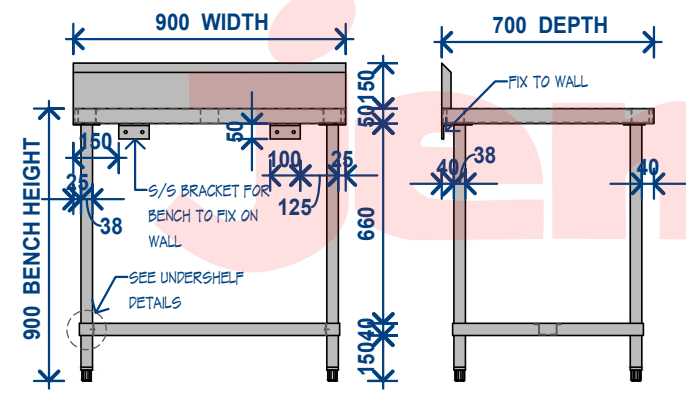

B-WB7-900 FRONT
Scale : 1 : 25M

B-WB7-900 SIDE
Scale : 1 : 25M



THIS DRAWING MUST NOT BE SCALED

THE CONTRACTOR SHALL VERIFY ALL DIMENSIONS, DATA AND LEVEL PRIOR TO THE COMMENCEMENT OF WORK. ALL ERRORS AND OMISSIONS BETWEEN THE DRAWINGS AND SPECIFICATION ARE TO BE REPORTED IMMEDIATELY.

-----© Copyright of Hospitality Equipment 2020 Pty. Ltd.-----

HE2020
HOSPITALITY EQUIPMENT 2020 PTY LTD

HOSPITALITY EQUIPMENT 2020 Pty. Ltd.

A: Unit 3/49-63 Victoria Street, Smithfield NSW 2164
P: 02 9637 3737
E: salesnsw@he2020.com.au
W: www.he2020.com.au

COMMERCIAL KITCHEN CONSULTANT

DRAWING TITLE: B-WB7-900			
DRAWN L.	DATE Sep. 27, 2021	SCALE As indicated (A4)	
PROJECT NO. 01	DRAWING NO. W4	REV. A1	