

# SSDR1

## S/S SINGLE DRAWER

**FEATURES:**

- Underwork top mountable
- **Dimensions:** W500 x D450 H220mm

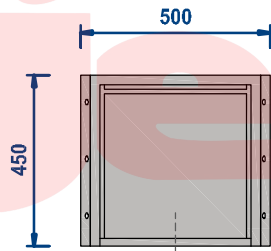

SSDR1 TOP  
Scale : 1 : 20M

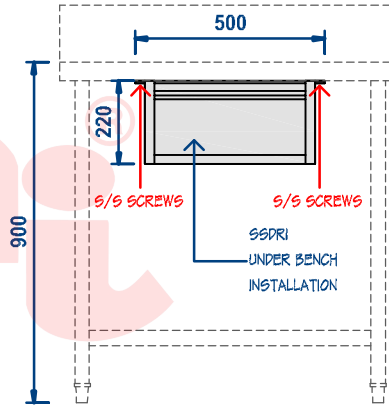

S/S SCREWS  
SSDR1  
UNDER BENCH  
INSTALLATION

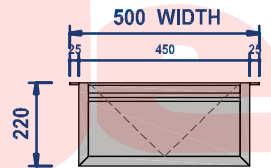

SSDR1 FRONT  
Scale : 1 : 20M

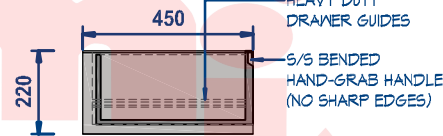

SSDR1 SIDE  
Scale : 1 : 20M



**THIS DRAWING MUST NOT BE SCALED**

THE CONTRACTOR SHALL VERIFY ALL DIMENSIONS, DATA AND LEVEL PRIOR TO THE COMMENCEMENT OF WORK. ALL ERRORS AND OMISSIONS BETWEEN THE DRAWINGS AND SPECIFICATION ARE TO BE REPORTED IMMEDIATELY.



-----© Copyright of Hospitality Equipment 2020 Pty. Ltd.-----



**HE2020**  
HOSPITALITY EQUIPMENT 2020 PTY LTD  
**HOSPITALITY EQUIPMENT**  
**2020 Pty. Ltd.**

A: Unit 3/49-63 Victoria Street,  
Smithfield NSW 2164  
P: 02 9637 3737  
E: salesnsw@he2020.com.au  
W: www.he2020.com.au

DRAWING TITLE:

**SSDR1**

DRAWN	L.	DATE	Sep. 27, 2021	SCALE	1 : 20	(A4)
PROJECT NO.	01	DRAWING NO.		REV.	A1	

COMMERCIAL KITCHEN CONSULTANT