

FEATURES:

- Underwork top mountable
- **Dimensions: W500 x D450 H670mm**

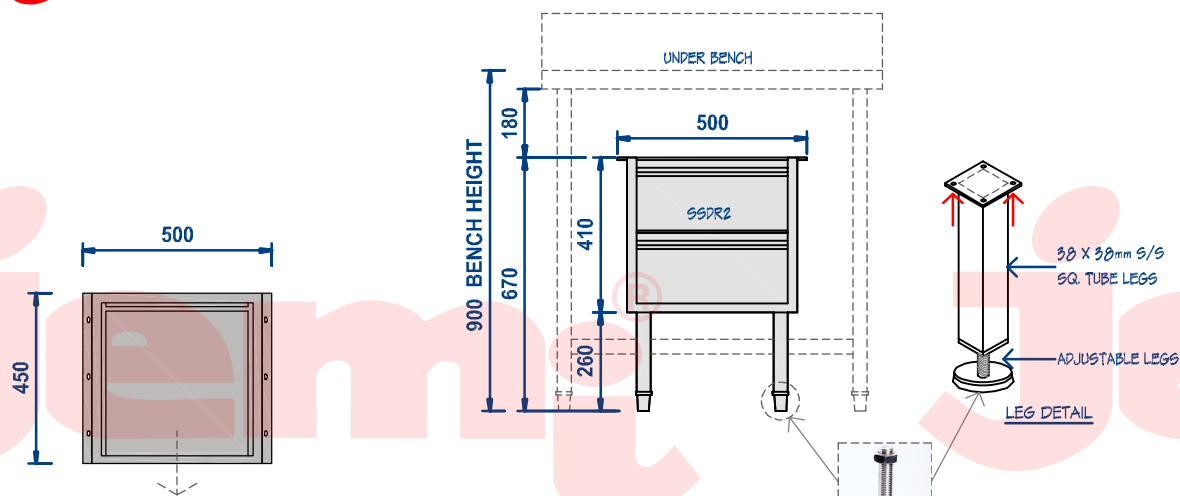

SSDR2 TOP
Scale : 1 : 20M

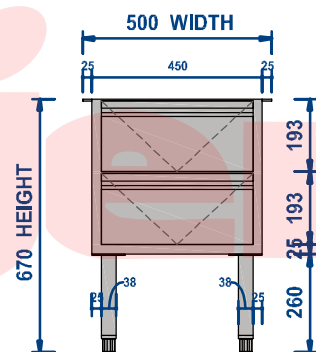

SSDR2 FRONT
Scale : 1 : 20M

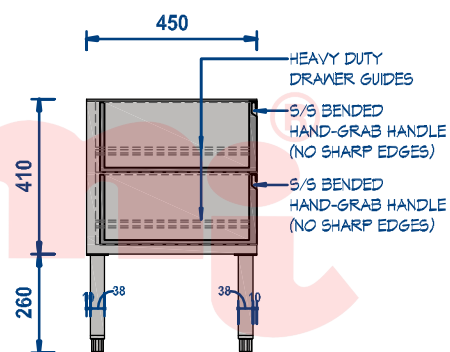

SSDR2 SIDE
Scale : 1 : 20M



THIS DRAWING MUST NOT BE SCALED

THE CONTRACTOR SHALL VERIFY ALL DIMENSIONS, DATA AND LEVEL PRIOR TO THE COMMENCEMENT OF WORK. ALL ERRORS AND OMISSIONS BETWEEN THE DRAWINGS AND SPECIFICATION ARE TO BE REPORTED IMMEDIATELY.



-----© Copyright of Hospitality Equipment 2020 Pty. Ltd.-----

HE2020
HOSPITALITY EQUIPMENT 2020 PTY LTD
HOSPITALITY EQUIPMENT
2020 Pty. Ltd.

A: Unit 3/49-63 Victoria Street,
Smithfield NSW 2164
P: 02 9637 3737
E: salesnsw@he2020.com.au
W: www.he2020.com.au

COMMERCIAL KITCHEN CONSULTANT

DRAWING TITLE:

SSDR2

DRAWN	L.	DATE	Sep. 27, 2021	SCALE	1 : 20 (A4)
PROJECT NO.	01	DRAWING NO.	B2	REV.	A1